

INSTALLATION INSTRUCTIONS

SIDE BARS
07 MAZDA CX7
PART NUMBER

PARTS LIST:

1	Passenger Side Bar	4	8-1.25mm x 25mm Hex Bolts
1	Driver Side Bar	4	8mm Lock Washers
2	Front Mounting Brackets (A)	4	8mm Flat Washers
2	Front Support Brackets (B)	2	10-1.50mm x 40mm Bolt Plates (E)
1	Rear P/S Mounting Bracket (D)	2	10mm Nylock Nut
1	Rear D/S Mounting Bracket (C)	2	10mm Flat Washers
4	6-1.00mm x 20mm Hex Bolts	2	12-1.75mm x 30mm Hex Bolts
4	6mm Nylock Nuts	2	12-1.75mm x 40mm Bolt Plates (F)
8	6mm Flat Washers	2	12mm Lock Washers
		2	12mm Nylock Nuts
		4	12mm Flat Washers

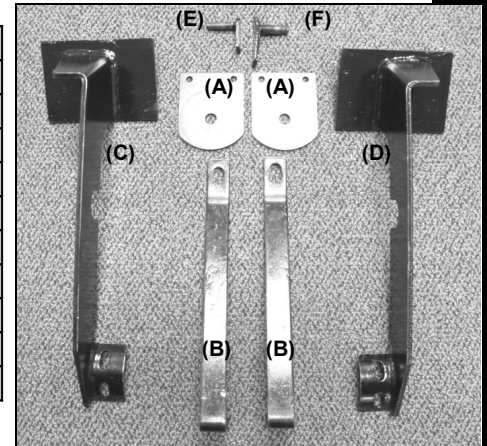

PROCEDURE:

1. REMOVE CONTENTS FROM BOX. VERIFY ALL PARTS ARE PRESENT. READ INSTRUCTIONS CAREFULLY.
2. Remove the two existing bolts from driver side pinch weld (Figure 1); do not remove the welded nuts. Replace these existing bolts with the included (2) 6-1.00mm x 20mm Hex Bolts and (2) 6mm Flat Washers **NOTE:** Insert Hex Bolts with Flat Washers trough welded nuts from the outer side of pinch weld (Figure 2). Tighten these bolts at this time.
3. Locate (1) Front Mounting Bracket and place it on the inner side of the pinch weld, on top of welded nuts and trough previously installed bolts in step 2. Secure Mounting Bracket with the included (2) 6mm Nylock Nut, and (2) 6mm Flat Washers (Figure 2). Do not tighten at this time.
4. Insert (1) 10-1.50mm x 40mm Bolt Plate trough the existing hole located by the driver side body mount (Figure 3).
5. Locate (1) Front Support Bracket and attach it to previously inserted Bolt Plate in step 4. Secure it with the included (1) 10mm Nylock Nut and (1) 10mm Flat Washer (Figure 2). Do not tighten at this time.
6. Insert (1) 12-1.75mm x 40mm Bolt Plate through the existing rear slotted hole on the frame (Figure 4).
7. Locate Rear Driver Side Mounting Bracket and attach it to previously inserted Bolt Plate in step 6. Secure it with the included (1) 12mm Nylock Nut and (1) 12mm Flat Washer (Figure 5). Do not tighten at this time.
8. With help carefully mount Driver Side Bar to Rear Mounting Bracket with the included (2) 8-1.25mm x 25mm Hex Head Bolts, (2) 8mm Lock Washers, and (2) 8mm Flat Washers (Figure 5). Do not tighten at this time.
9. Mount Driver Side Bar and Front Support Bracket to already installed Front Mounting Bracket using the same included (1) 12-1.75mm x 30mm Hex Head Bolt, (1) 12mm Lock Washer, and (1) 12mm Flat Washer (Figure 2). Do not tighten at this time.
10. Level and adjust Side Bar, then tighten all hardware at this time.

11. Repeat steps 2-10 for Passenger Side Bar.

12. Do periodic inspections to the installation to make sure that all hardware is secure and tight.

(Driver Side Shown)

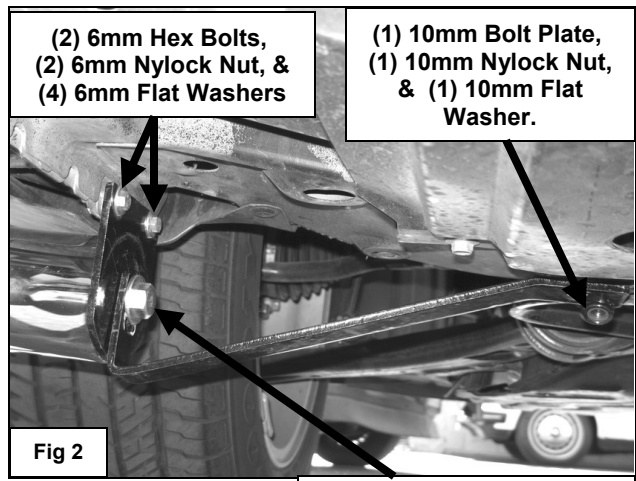
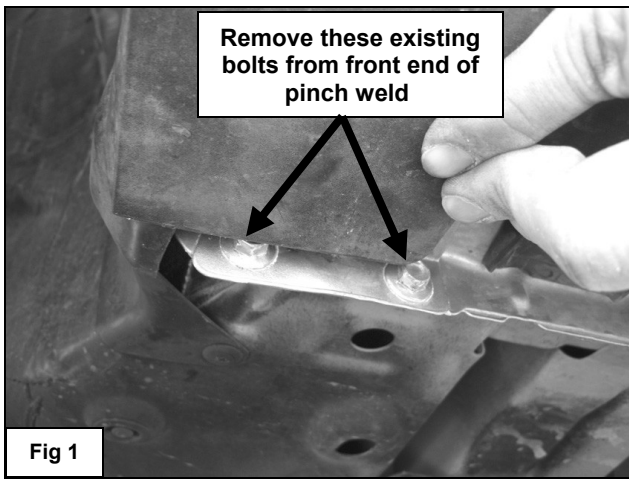

(1) 12mm Hex Bolt,
(1) 12mm Lock Washer, &
(1) 12mm Flat Washers

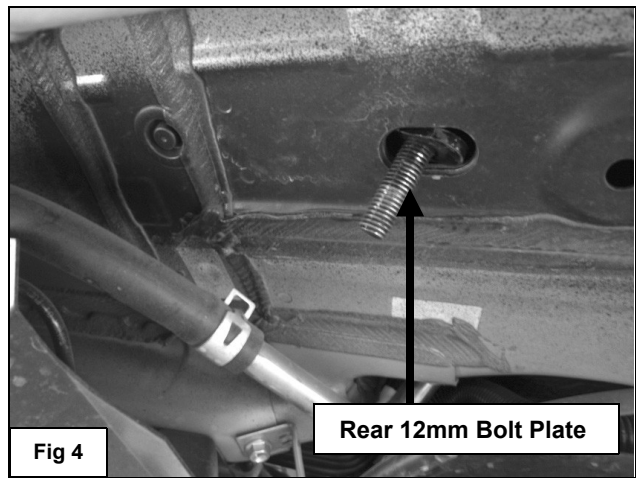
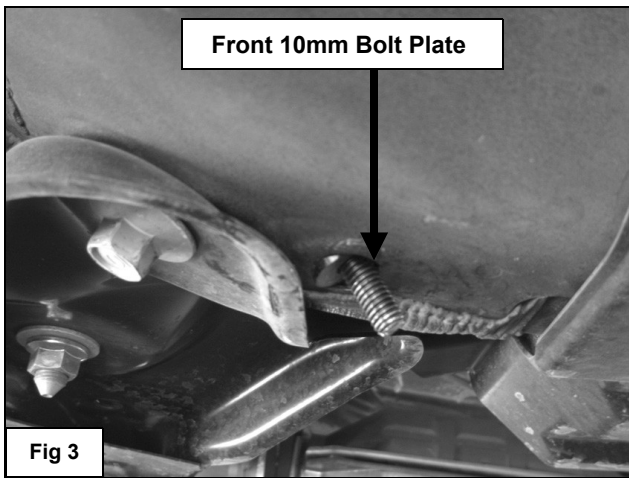

Driver Side Rear Bracket Shown

(2) 8mm Hex Bolts,
(2) 8mm Lock Washers,
& (2) 8mm Flat Washers



(1) 12mm Bolt Plate,
(1) 12mm Nylock Nut, &
(1) 12mm Flat Washers

Fig 5