

Installation Instruction

Bull Bar Part #

1999-06 SILVERADO 2500LD
2001-06 SIL 1500HD/2500HD/3500HD
2000-06 SUBURBAN/TAHOE 2500
2001-06 AVALANCHE 2500
(both w/ and w/out clad)

QTY.	ITEM	<u>CONTENT</u>
1	1	BULL BAR
2	2	BRACKETS-PASSENGER & DRIVER SIDE
2	3	SPACER PLATE
4	4	RUBBER BUMPER
4	5	1/2 -13 X 2.00" HEX HEAD BOLT
4	6	1/2" FLAT WASHERS
4	7	1/2" LOCK WASHERS
4	8	3/8" -16 X 1.25 HEX HEAD BOLT
8	9	3/8" FLATE WASHER
4	10	3/8 LOCK WASHER
4	11	3/8-16 HEX NUT
2	12	M12- 1.75 X 40MM HEX HEAD BOLT
2	13	M12-1.75 HEX NUT

STEP 1 REMOVE CONTENTS FROM BOX AND VERIFY ALL PART ARE PRESENT. READ INSTRUCTIONS COMPLETELY BEFORE BEGINNING.

STEP 2 IT MAY BE NECESSARY TO REMOVE/RELOCATE FRONT LICENSE PLATE AND LICENSE PLATE BRACKET. IT IS NOT REQUIRED, BUT SRONGLY RECOMMENDED.

STEP 3 DETERMINE PASSENGER AND DRIVER BRACKETS. FROM UNDERNEATH VEHICLE, REMOVE TOW HOOKS. SLIDE BRACKETS THROUGH END FRAME AND ALIGN HOLES IN BOTTOM OF FRAME WITH THE TWO NUTS WELDED TO THE BRACKETS. ATTACH BRACKETS TO FRAME RAIL WITH 1/2" FASTENERS AS SHOWN. **NOTE:** USE ONE SPACER PLATE FOR LARGE HOLE IN BOTTOM OF FRAME AS SHOWN. LEAVE LOOSE. NOTE FOR VEHICLES WITHOUT TOW HOOKS A SMALL OPENING MAY NEED TO BE CUT OUT IN THE TWO INSIDE INDENTS OF THE AIRDAM USING A UTILITY KNIFE. SEE FIGURE 3.

STEP 4 ATTACH HOOP MOUNTS BRACKETS TO FRAME BRACKETS USING 3/8" FASTNERS AS SHOWN . **NOTE:** 1999-02 MODELS USE FRONT AND MIDDLE HOLES ON THE LOOP MOUNTING BRACKETS. 2003 UP MODELS USE MIDDLE AND REAR HOLES. SEE FIGURE 2.

STEP 5 LEVEL AND ADJUST BULL BAR AS DESIRED. TORQUE 1/2" FASTENERS TO 65 FT.LBS AND 3/8" FASTENERS TO 30 FT. LBS.

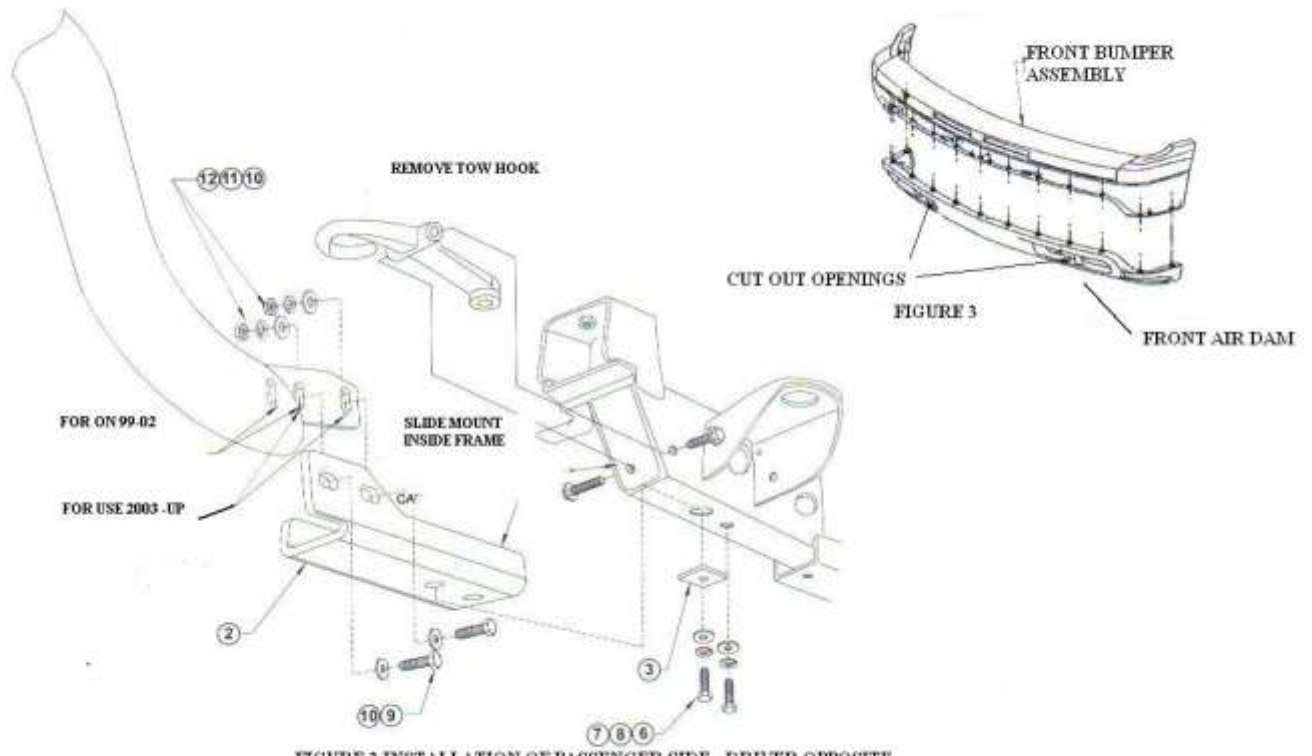

FIGURE 2 INSTALLATION OF PASSENGER SIDE- DRIVER OPPOSITE