

INSTALLATION INSTRUCTIONS

BULL BAR 08 FORD ESCAPE PART NUMBER

PARTS LIST:

1	Bull Bar	4	10mm Nylock Nuts
1	Driver/Left Mounting Bracket (A)	4	10mm ID x 26mm OD x 2mm Flat Washers
1	Passenger/Right Mounting Bracket (B)	2	8-1.25mm x 25mm Bolt Plate
1	Driver/Left Bull Bar Bracket (C)	2	8mm Nylock Nuts
1	Passenger/Right Bull Bar Bracket (D)	2	8mm ID x 22mm OD x 2mm Flat Washers
2	Top Brackets (E)	4	12-1.75mm x 30mm Hex Head Bolts
2	10-1.50mm U-Bolts	4	12mm Nylock Nuts
2	12-1.75mm x 50mm Hex Head Bolts	10	12mm ID x 29mm OD x 3mm Flat Washers
2	12mm Lock Washers		

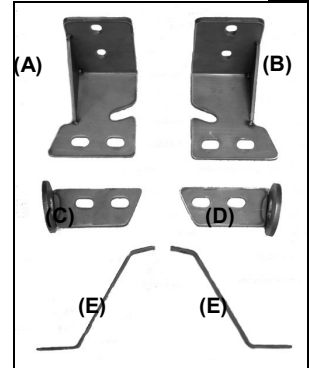

PROCEDURE:

- 1. REMOVE CONTENTS FROM BOX. VERIFY ALL PARTS ARE PRESENT. READ INSTRUCTIONS CAREFULLY BEFORE STARTING INSTALLATION. DO NOT ATTEMPT INSTALLATION ALONE; PERSONAL INJURY OR DAMAGE TO THE TRUCK MAY RESULT.**
- From underside of vehicle, remove the front factory plastic shroud and the air dam and set aside.
- Using a hacksaw cut out 1 ¼" gap on each marked location on the air dam shown in **Figure 1 & 2**. **NOTE:** The air dam will be in three pieces, when re-installing.
- Cut out a 1 ¾" x 4" gap on each marked location on both plastic shrouds as shown in **Figure 1 & 2**. Once the air dam and plastic shroud are both cut, set them aside.
- Locate the two non-threaded factory holes on the passenger side of the cross member and insert (1) 10mm "U" Bolt through factory hole as shown in **Figure 3**.
- Position passenger side Mounting Bracket onto cross member and through already installed "U" Bolt. Secure Mounting Bracket to "U" Bolt using (2) 10mm Nylock Nuts and (2) 10mm Flat Washers (**Figure 4**). Do not tighten at this time.
- Repeat steps 5 & 6 for driver side Mounting Bracket.
- On each of the outer bumper intake there is one plastic fastener on the upper section. Use a flat screw driver to remove these plastic fasteners (**Figure 5**).
- Engage (1 ea) 8mm x 25mm Bolt Plate through the top of each factory hole where you previously removed the plastic fasteners (**Figure 6**).
- Partially hang Top Brackets to already installed Bolt Plates by using (1) 8mm Nylock Nut and (1) 8mm Flat Washer (**Figure 7**). Do not tighten at this time.
- Remove the two outer skid plate upper bolts on the Bull Bar (**Figure 8**). **NOTE:** This will be the Top Bracket mounting location.
- Determine passenger and driver Bull Bar Mounting Brackets and hand tighten them to Bull Bar using (2) 12-1.75mm Hex Head Bolts, (2) 12mm Lock Washers, and (2) 12mm Flat Washers (**Figure 9**).
- With help position Bull Bar on the outer side of Mounting Brackets. Attach Bull Bar to Mounting Brackets using (4) 12mm x 30mm Hex Head Bolts, (4) 12mm Nylock Nuts, and (8) 12mm Flat Washers (**Figure 10**). Do not tighten at this time.
- Attach Top Bracket to Bull Bar using the bolts removed in step 11 (**Figure 11**).
- Level and adjust Bull Bar; and then tighten all hardware at this time.

- 16. Re-install plastic shroud and air dam using the factory hardware.
- 17. Do periodic inspections to the installation to make sure that all hardware is secure and tight.

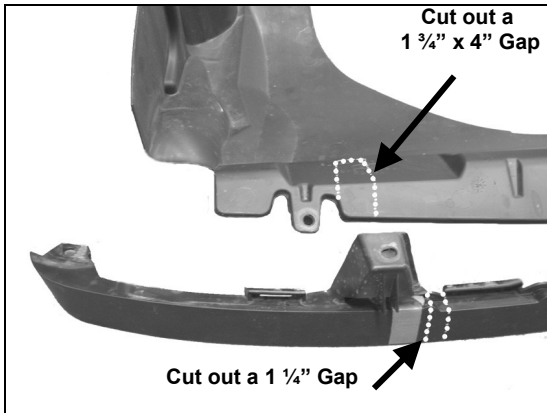

Figure 1

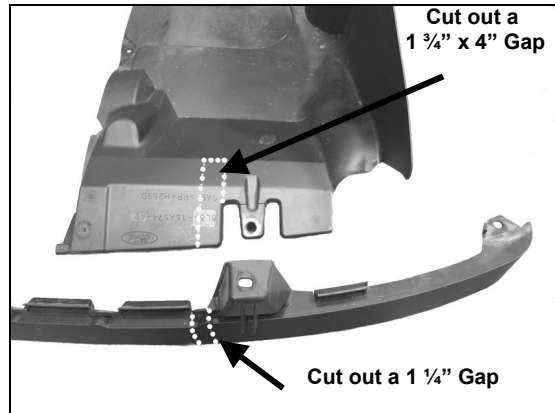

Figure 2

(Passenger Side Installation Shown)

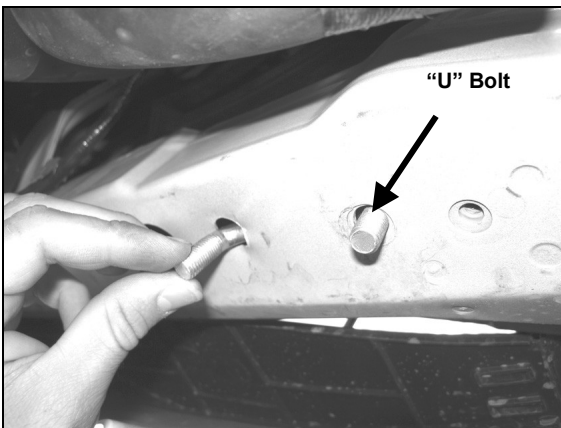

Figure 3

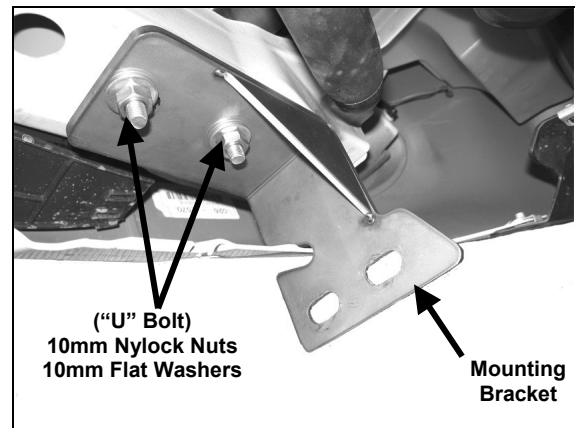

Figure 4

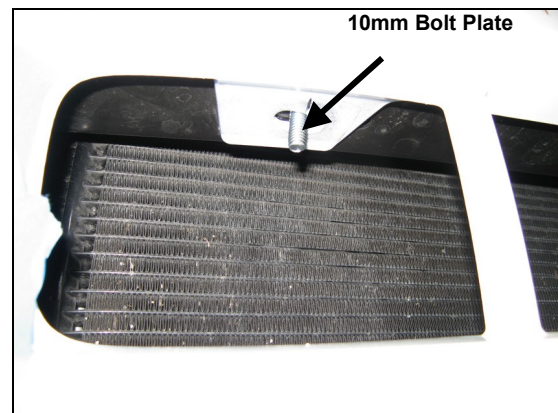
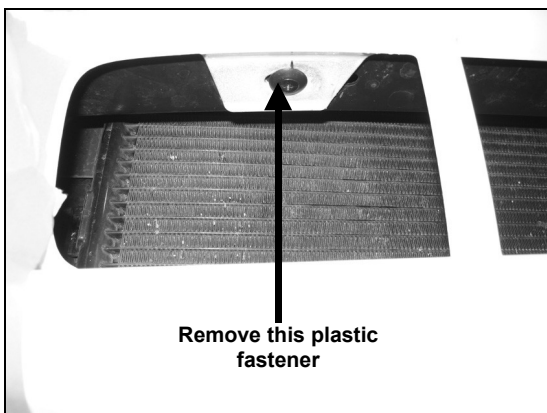

Figure 5

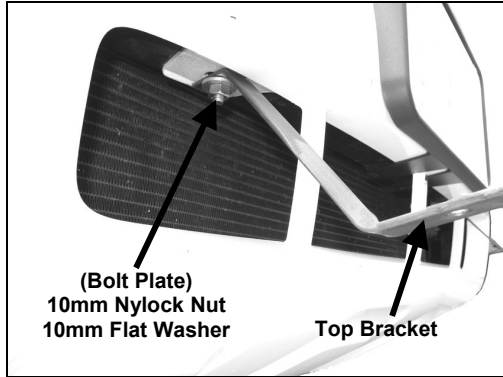

Figure 7

Figure 6

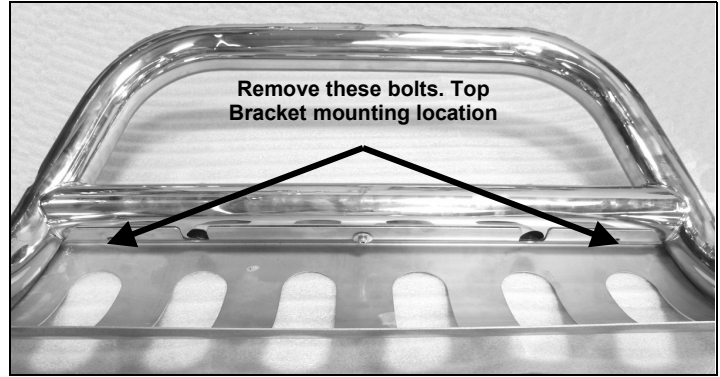

Figure 8

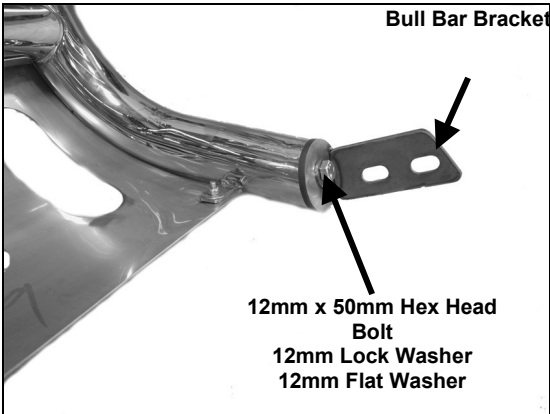

Figure 9

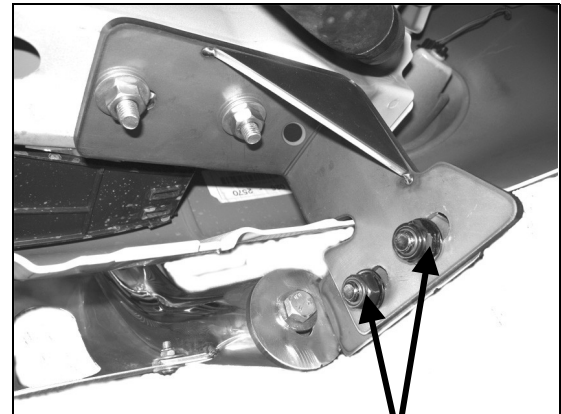

Figure 10

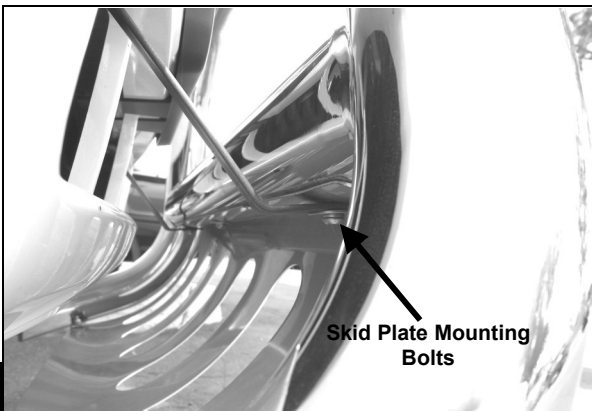

Figure 11



Figure 12