

PARTS LIST:

1	Sport Bar	4	10mm Hex Nut
2	Frame Mounting Brackets	4	10mm Nylon Lock Nut
1	10-1.5mm x 125mm x 110mm U-Bolt (Driver Side Use Only)	1	8-1.25mm x 100mm Hex Bolt (Driver Side Use Only)
1	10-1.5mm x 125mm x 95mm U-Bolt (Passenger Side Use Only)	1	8-1.25mm x 80mm Hex Bolt (Passenger Side Use Only)
4	10-1.5mm x 25mm Hex Bolt	4	8mm x 24mm x 2mm Flat Washers
12	10mm x 30mm OD x 2.5mm Flat Washer	2	8mm Lock Washers
4	10mm Lock Washer	2	8mm Hex Nuts

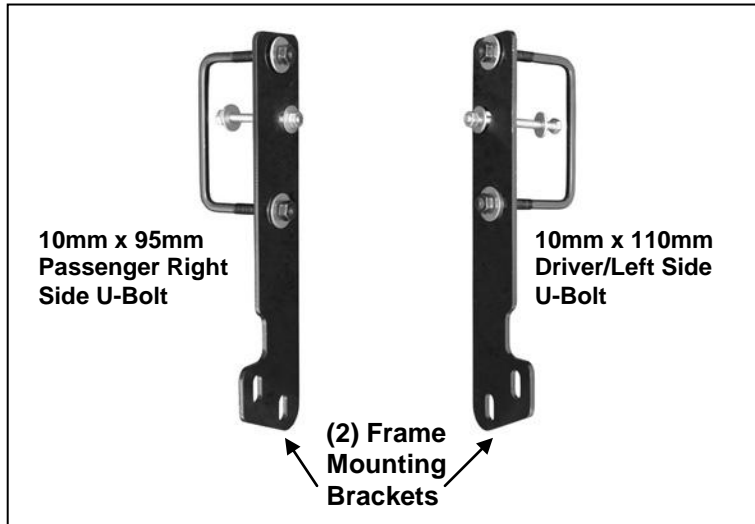

PROCEDURE:

- 1. REMOVE CONTENTS FROM BOX. VERIFY ALL PARTS ARE PRESENT. READ INSTRUCTIONS CAREFULLY. CUTTING IS REQUIRED.**
- Remove the factory splash guard located under the front bumper, **(Figure 10A)**. Note the location and type of all factory fasteners to make reinstallation easier. **VERY IMPORTANT:** Check the top of the frame on driver and passenger side for wiring harness. Release plastic clip from top of frame to temporarily move wiring harness before beginning installation.
- Start installation under the driver side front of the vehicle. Locate the factory hole in the side of the frame channel approximately mid-way up the side of the frame. From the outside of the frame channel, insert (1) 8mm x 100mm Hex Bolt with (1) 8mm Flat Washer into and out through the factory holes in the frame channel, **(Figure 1)**. Select (1) Frame Mounting Bracket, **(Figure 2)**. Line up the hole in the middle of the Bracket between the (2) slots with the previously installed Hex Bolt and secure with (1) 8mm Flat Washer, (1) 8mm Lock Washer and (1) 8mm Hex Nut, **(Figure 3)**. Place the longer 10mm x 110mm U-Bolt around the frame channel and through the slots in the Frame Bracket, **(Figure 4)**. **IMPORTANT:** Verify that the wiring harness on top of the frame, **(Step 2)**, is clear before installing U-Bolt. Secure the U-Bolt to the Frame Bracket with (2) 10mm Flat Washers, (2) 10mm Lock Washers and (2) 10mm Hex Nuts, **(Figure 5)**. Snug but do not tighten hardware at this time.
- Repeat Step 3 for the passenger side Frame Bracket installation except use the shorter 10mm x 95mm U-Bolt and 8mm x 80mm Hex Bolt hardware, **(Figure 6A & 6B)**.
- Bolt the Sport Bar to the Brackets with the included (4) 10mm x 25mm Hex Bolts, (8) 10mm Flat Washers and (4) 10mm Nylon Lock Nuts, **(Figures 7)**. Align and adjust the Sport Bar. **NOTE:** It may be necessary to loosen and adjust the location of the Frame Brackets on the frame channel. Retighten the hardware bolting the Mounting Brackets to the frame only once fully satisfied with the adjustment.
- Once the Sport Bar has been properly aligned and adjusted, tighten the Frame Bracket hardware only including the U-Bolts. Remove the Sport Bar, (leave Frame Brackets in place-, **(Figure 8)**). Hold the

SPORT BAR 2011 KIA SPORTAGE

factory splash guard up in its original position, **(Figure 9)**. Mark the Frame Bracket location onto the back of the splash guard and cut an approximately 10mm x 100mm slot out of each side of the splash guard, **(Figures 10A & 10B)**. Make many small cuts to get the best fit possible. **IMPORTANT:** To maintain the splash guard's strength, do not cut completely through the front edge of the splash guard. Only remove enough material from the splash guard to clear the Brackets. Reinstall the splash guard over the Brackets using the factory hardware.

7. Bolt the Sport Bar to the Frame Brackets with the 10mm hardware described in **Step 5, (Figure 8)**. Adjust and align the Sport Bar if necessary and tighten all hardware.
8. Do periodic inspections to the installation to make sure that all hardware is secure and tight.

To protect your investment, wax this product after installing. Regular waxing is recommended to add a protective layer over the finish. Do not use any type of polish or wax that may contain abrasives that could damage the finish.

For stainless steel: Aluminum polish may be used to polish small scratches and scuffs on the finish. Mild soap may be used also to clean the Sport Bar.

For gloss black finishes: Mild soap may be used to clean the Sport Bar.

Passenger Side Installation Pictured

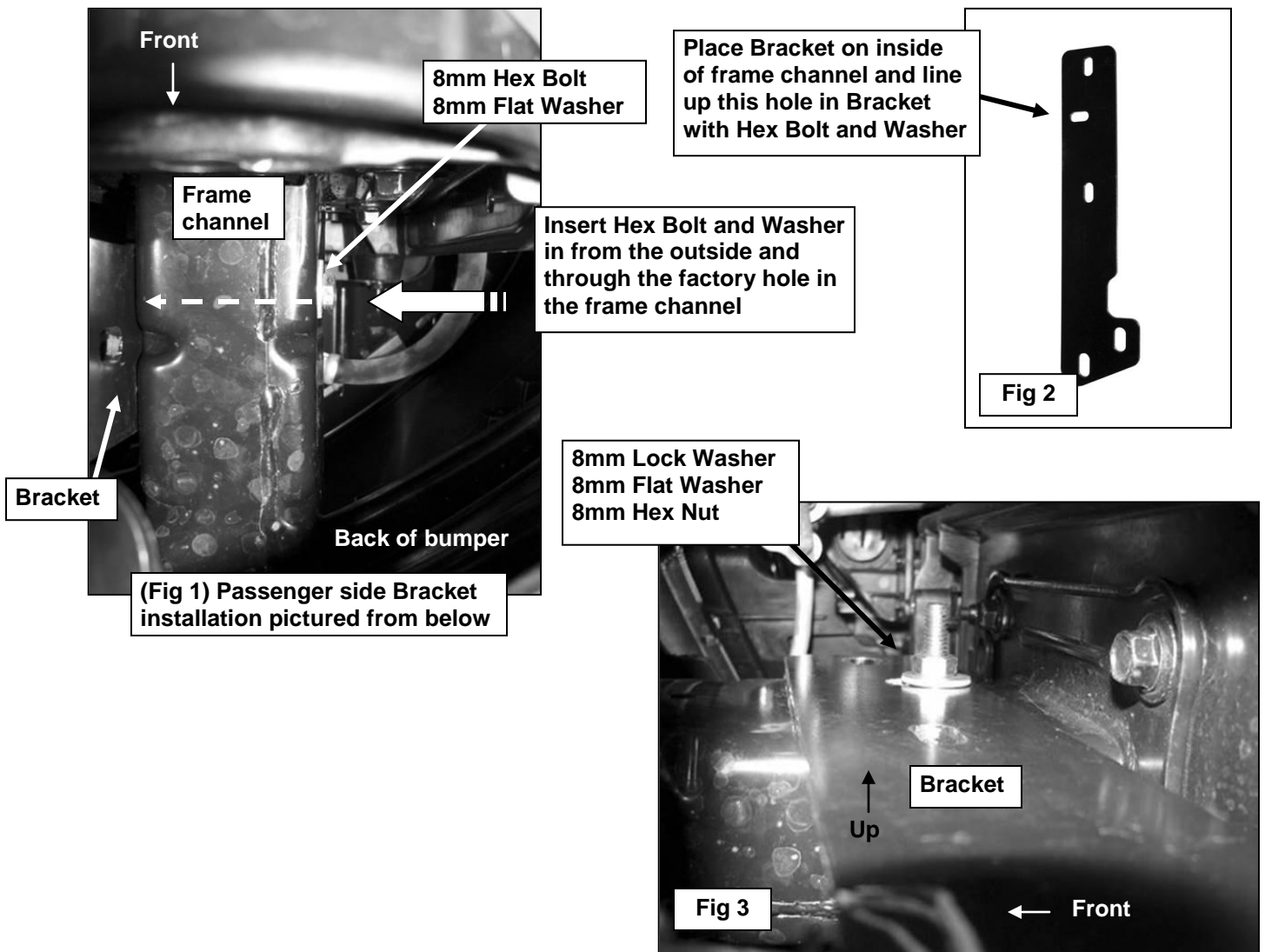

Passenger Side Installation Pictured

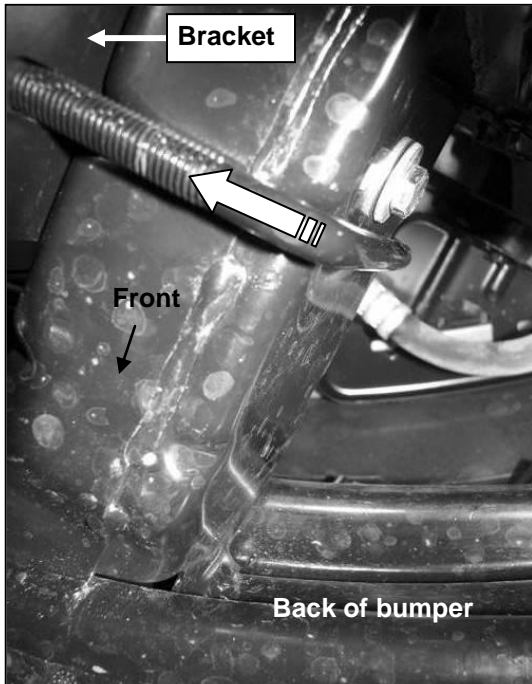

- 10mm U-Bolt
- (2) 10mm Flat Washers
- (2) 10mm Lock Washers
- (2) 10mm Hex Nuts

- 8mm Lock Washer
- 8mm Flat Washer
- 8mm Hex Nut

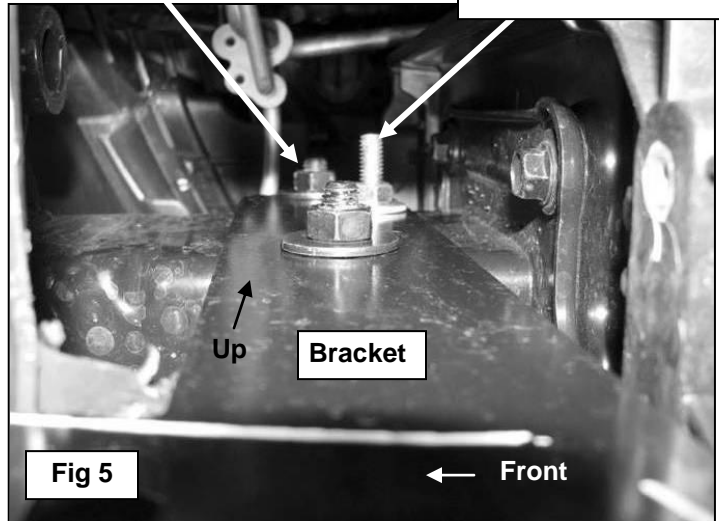
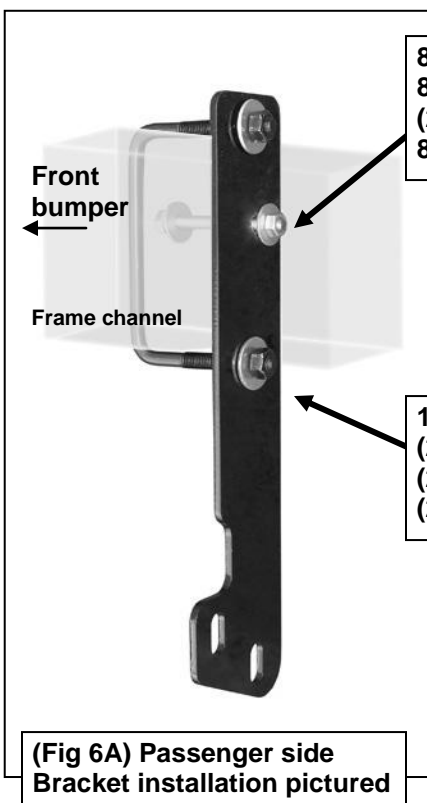

Fig 5

(Fig 4) Slide U-Bolt around frame channel and through Bracket-passenger side pictured from below

- 10mm x 110mm U-Bolt
- (2) 10mm Flat Washers
- (2) 10mm Lock Washers
- (2) 10mm Hex Nuts



- 8mm x 80mm Hex Bolt
- 8mm Lock Washer
- (2) 8mm Flat Washers
- 8mm Hex Nut

- 8mm x 100mm Hex Bolt
- 8mm Lock Washer
- (2) 8mm Flat Washers
- 8mm Hex Nut

- 10mm x 95mm U-Bolt
- (2) 10mm Flat Washers
- (2) 10mm Lock Washers
- (2) 10mm Hex Nuts

(Fig 6A) Passenger side Bracket installation pictured

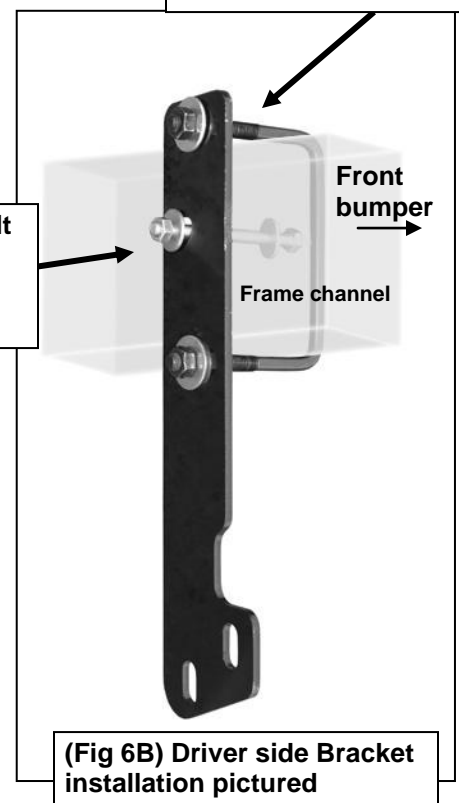

(Fig 6B) Driver side Bracket installation pictured

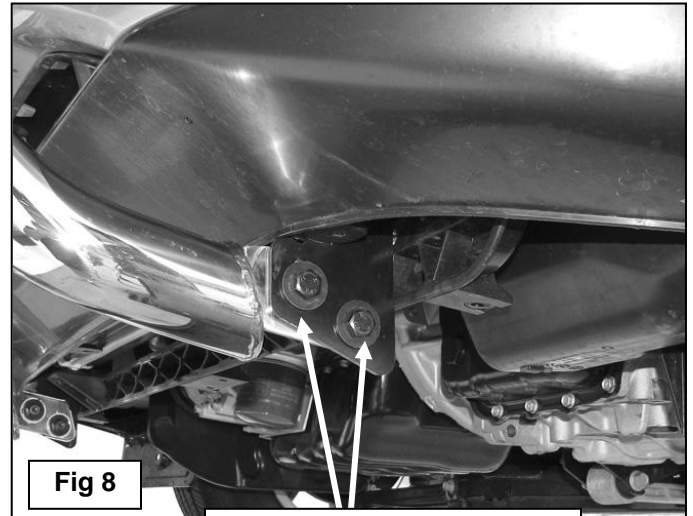
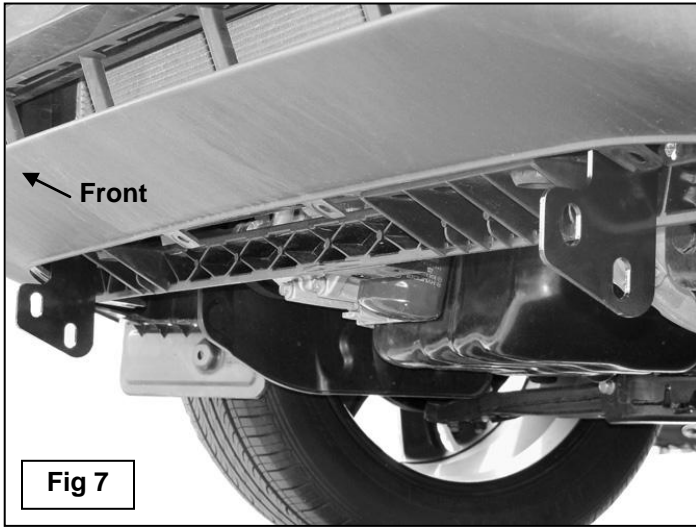

(2) 10mm x 25mm Hex Bolts
(4) 10mm Flat Washers
(2) 10mm Nylon Lock Nuts

