

INSTALLATION INSTRUCTIONS
REAR BUMPER GUARD (Single Tube)
07 FORD EDGE
PART NUMBER

PARTS LIST:

1	Rear Bumper Guard	4	12-1.75mm x 35mm Hex Head Bolts
1	Driver/Left Frame Bracket	8	12mm ID x 29mm OD x 3mm Flat Washers
1	Passenger/Right Frame Bracket	4	12mm Nylock Nuts
1	Driver/Left Bumper Guard Bracket	4	8-1.25mm x 25mm Hex Head Bolts
1	Passenger/Right Bumper Guard Bracket	4	8mm Lock Washers
2	10mm Double Bolt Plates	4	8mm ID x 22mm OD x 1.5mm Flat Washers
4	10mm Nylock Nuts		
4	10mm ID x 26mm OD x 3mm Flat Washers		

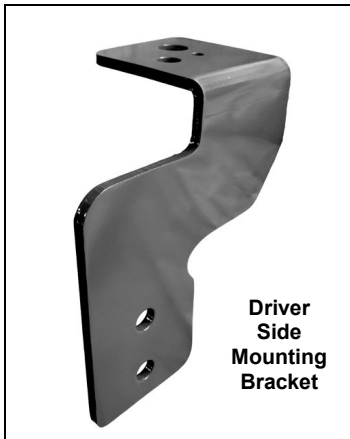

PROCEDURE:

1. REMOVE CONTENTS FROM BOX. VERIFY ALL PARTS ARE PRESENT. READ INSTRUCTIONS CAREFULLY BEFORE STARTING INSTALLATION. CUTTING REQUIRED
2. On the driver's side of the vehicle locate the heat shield right above the muffler. There are two bolts on the outer side of the vehicle and one bolt on the inner side of vehicle that holds the heat shield to the vehicle, remove these bolts and place heat shield aside. Use a metal cutting scissors to cut the marked area as shown in **Figure 1**.
3. Once you have cut the marked area, reposition the heat shield back to the vehicle. Use the factory hardware to re-install it. **NOTE:** Do not install the bolt that mounts next to the factory holes on the frame rail at this time (**Figure 2**).
4. Insert one end of Double Bolt Plate through bigger hole on the frame rail so inner bolt drops through smaller factory hole (**Figure 3**).
5. Partially hang driver side Mounting Bracket to already inserted Double Bolt Plates using the included (2) 10mm Nylock Nuts, (2) 10mm Flat Washers, and factory bolt from heat shell (**Figure 4**). Do not tighten at this time.
6. Position driver side Rear Bumper Guard Bracket on the inner side of the driver side Mounting Bracket. Use the included (2) 12mm x 35mm Hex Head Bolts, (2) 12mm Nylock Nuts, and (4) 12mm Flat Washers (**Figure 5**). Do not tighten at this time. **NOTE:** Cradles on the Rear Bumper Guard Brackets should be facing towards the side of the vehicle.
7. Repeat steps 2 & 6 for passenger side Mounting Bracket and Rear Bumper Guard Bracket.
8. Once all the Brackets are partially install, position Rear Bumper Guard onto Brackets. Use the included (4) 8mm x 25mm Hex Head Bolts, (4) 8mm Lock Washers, and (4) 8mm Flat Washers to attach Rear Bumper Guard to Brackets (**Figure 6**).
9. Adjust the Rear Bumper Guard properly, and then tighten all hardware at t his time.
10. Do periodic inspections to the installation to make sure that all hardware is secure and tight.
11. To protect your investment, wax this product after installing. Regular waxing is recommended to add a protective layer over the finish. Do not use any type of polish or wax that may contain abrasives that could damage the finish.

For stainless steel: Aluminum polish may be used to polish small scratches and scuffs on the finish. Mild soap may be used also to clean the Rear Bumper Guard.

For gloss black finishes: Mild soap may be used to clean the Rear Bumper Guard.

(Driver Side Installation Shown)

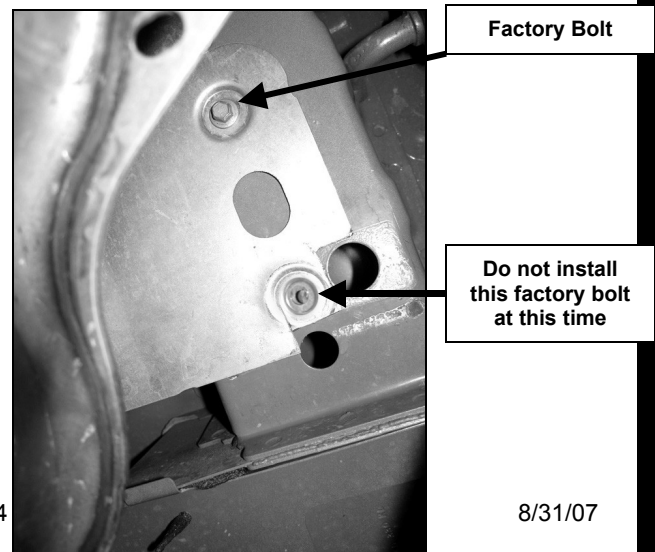
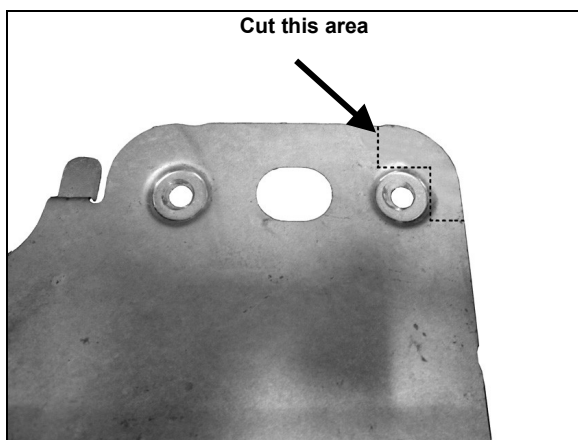

Fig 1

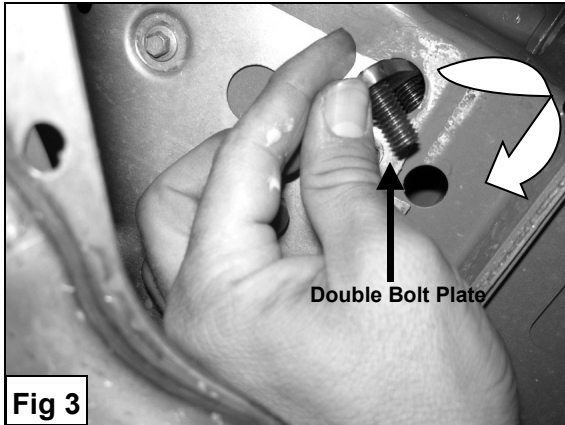
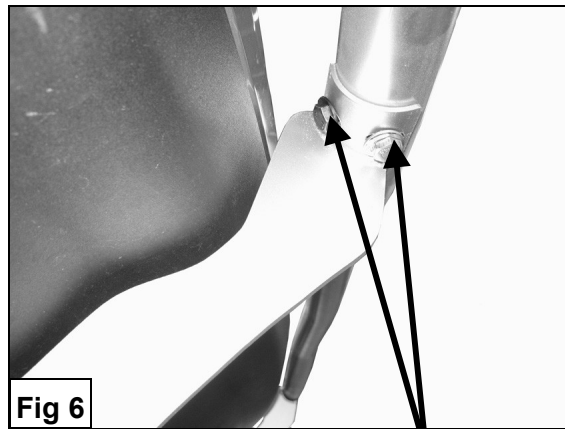
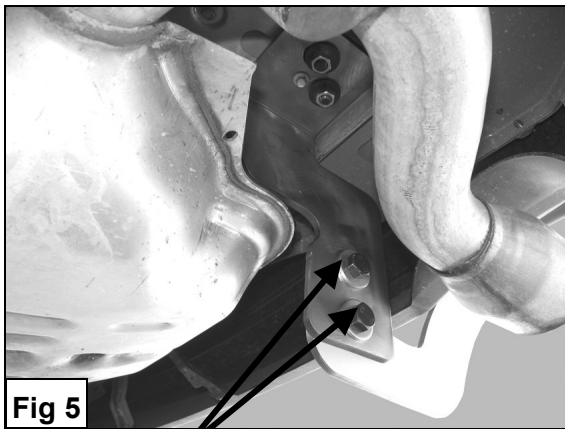
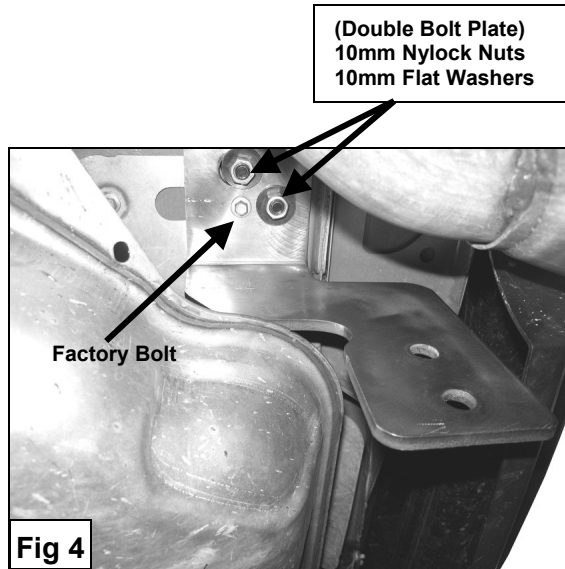

Fig 2



Installation Complete



Fig 7